



INSTRUCTION MANUAL

EndOhm

Tissue Resistance Measurement Chambers
For Tissue Culture Cups

CONTENTS

ABOUT THIS MANUAL	1
INTRODUCTION	2
Notes and Warnings.....	2
Parts List.....	3
Unpacking.....	3
INSTRUMENT DESCRIPTION	4
Instrument Description	4
Setup	4
Adjusting the Height of the Top Electrode.....	4
Electrode Preparation	5
OPERATING INSTRUCTIONS.....	6
Voltage Measurements	6
Resistance Measurements	7
MAINTENANCE	9
Cleaning.....	9
Storage	9
Sterilization.....	10
Re-Chloriding the Electrode	10
ACCESSORIES.....	11
TROUBLESHOOTING	12
APPENDIX A: RESISTANCE CALCULATIONS	14
Resistance.....	14
Resistance value of the “blank” insert.....	14
Unit Area Resistance	14
APPENDIX B: TESTING THE ENDOHM.....	16
INDEX.....	18
WARRANTY	19
Claims and Returns	19
Repairs.....	19

Copyright © 2024 by World Precision Instruments, Inc. All rights reserved. No part of this publication may be reproduced or translated into any language, in any form, without prior written permission of World Precision Instruments, Inc.

ABOUT THIS MANUAL

The following symbols are used in this guide:



This symbol indicates a CAUTION. Cautions warn against actions that can cause damage to equipment. Please read these carefully.



This symbol indicates a WARNING. Warnings alert you to actions that can cause personal injury or pose a physical threat. Please read these carefully.

NOTES and TIPS contain helpful information.



Fig. 1—Endohm-6G, Endohm-12G and Endohm-24G

INTRODUCTION

The **EndOhm** series of chambers, when used with WPI's **EVOM™ Manual** resistance meter or the Millicell ERS, are designed to provide reproducible and accurate resistance measurements of endothelial tissue in culture cups. Resistance values obtained with the **EndOhm** are consistent with those obtained using a well-designed Ussing Chamber.

- **EVM-EL-03-01-01 (ENDOHM-6)** Chamber for 6mm culture cup, 15.8mm ID (24 wells per plate)
- **EVM-EL-03-01-02 (ENDOHM-12)** Chamber for 12mm culture cup, 23.2mm ID (12 wells per plate)
- **EVM-EL-03-01-03 (ENDOHM-24)** Chamber for 24mm and COSTAR Snapwell™ culture cup, 37.3mm ID (6 wells per plate)

The **EndOhm** chamber and cap each contain a pair of concentric electrodes. Current flows between these symmetrically opposing circular disc electrodes. This design provides several advantages:

- Current density across the membrane is more uniform with **EndOhm's** circular disc current electrodes than with the **STX4** electrodes.
- Most importantly, with **EndOhm's** fixed electrode geometry, variation between successive resistance measurements of the same sample is reduced from 10-30 Ω (variation is dependent on the experience of the user) to 1-2 Ω .

Notes and Warnings

NOTE: EndOhm chambers have Ag/AgCl electrodes. If you are planning to do continuous data recording for extended period, you may need to take into consideration any potential cytotoxic effects of long-term exposure of silver on your specific cell type.



CAUTION: The glass chamber is easier to clean and more scratch resistant than the prior versions. The EndOhm is not recommended for incubator use due to risk of the glass cracking.



CAUTION: Long-term storage in a UV hood could cause cracking in the clear plastic chamber.



CAUTION: DO NOT AUTOCLAVE THE ENDOHM. Autoclaving can cause the transparent section of the chamber to become crazed. Repeated autoclaving might also damage the seal of the electrode.

Parts List

After unpacking, verify that there is no visible damage to the unit. Verify that all items are included:

(1) **EndOhm** chamber

(1) Spacer disk (4mm for ENDOHM-6G or 6mm for ENDOHM-12G or ENDOHM-24G-SNAP)

(1) EndOhm cable

(1) Instruction Manual is available online at <https://www.wpiinc.com/manuals>.

Unpacking

Upon receipt of this instrument, make a thorough inspection of the contents and check for possible damage. Missing cartons or obvious damage to cartons should be noted on the delivery receipt before signing. Concealed damage should be reported at once to the carrier and an inspection requested. Please read the section entitled "Claims and Returns" on page 19 of this manual. Please contact WPI Customer Service if any parts are missing at 941.371.1003 or customerservice@wpiinc.com.

Returns: Do not return any goods to WPI without obtaining prior approval (RMA # required) and instructions from WPI's Returns Department. Goods returned (unauthorized) by collect freight may be refused. If a return shipment is necessary, use the original container, if possible. If the original container is not available, use a suitable substitute that is rigid and of adequate size. Wrap the instrument in paper or plastic surrounded with at least 100mm (four inches) of shock absorbing material. For further details, please read the section entitled "Claims and Returns" on page 19 of this manual.

INSTRUMENT DESCRIPTION

Instrument Description

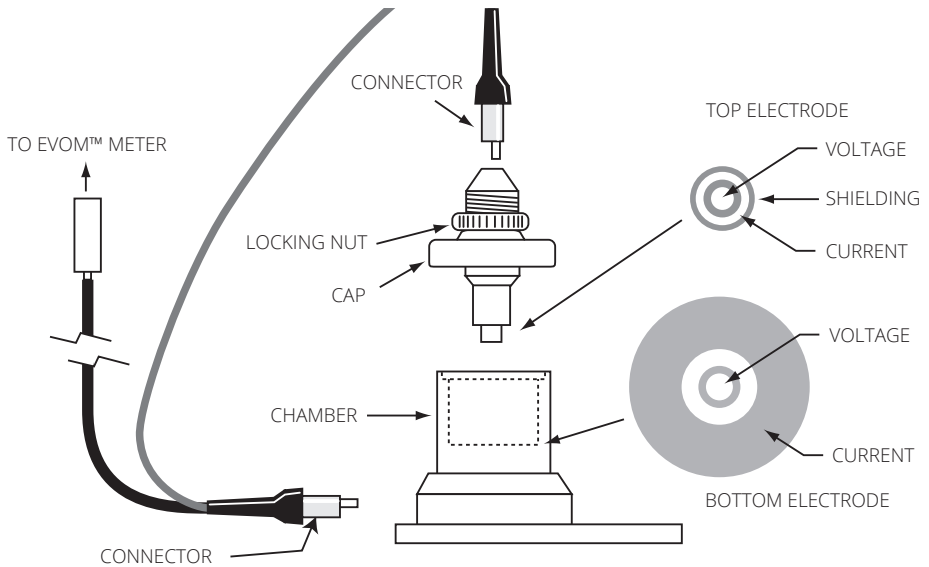

Fig. 2—Schematic diagram of an EndOhm

The structure of the **EndOhm** is pictured in Fig. 2. Each pair of concentric electrodes incorporates a voltage-sensing Ag/AgCl pellet in the center and an annular current electrode. The current electrode is made of silver and coated with gray-colored silver chloride. The top cap assembly is composed of three parts — cap, locking nut, and electrode. The cap has two important functions: it helps to center the electrode in the culture cup and, together with the locking nut, fixes the height of the electrode in the chamber. The cable connecting the chamber to the **EVOM™ Manual** can be easily disconnected from both the top cap assembly and the bottom chamber.

Setup

Adjusting the Height of the Top Electrode

The height of the top electrode of all the **EndOhms** can be adjusted to fit cell culture cups from different manufacturers.

1. Before use, place a blank cup into the chamber.
2. Loosen the locking nut on the cap assembly.

3. Rotate the cap on the top electrode to change the height of the electrode. When the cap is in place on top of the chamber, the clearance between the top electrode and the culture membrane should be 1–2mm (Fig. 3).

NOTE: The height setting of the upper electrode is variable, but it must be set low enough so that the annular current electrode is immersed in the apical media. Once the upper electrode height is set, it should not be changed. Changing the height of the upper electrode can change the TEER readings. In general, lowering the upper electrode decreases the reading, and raising the electrode increases the reading.

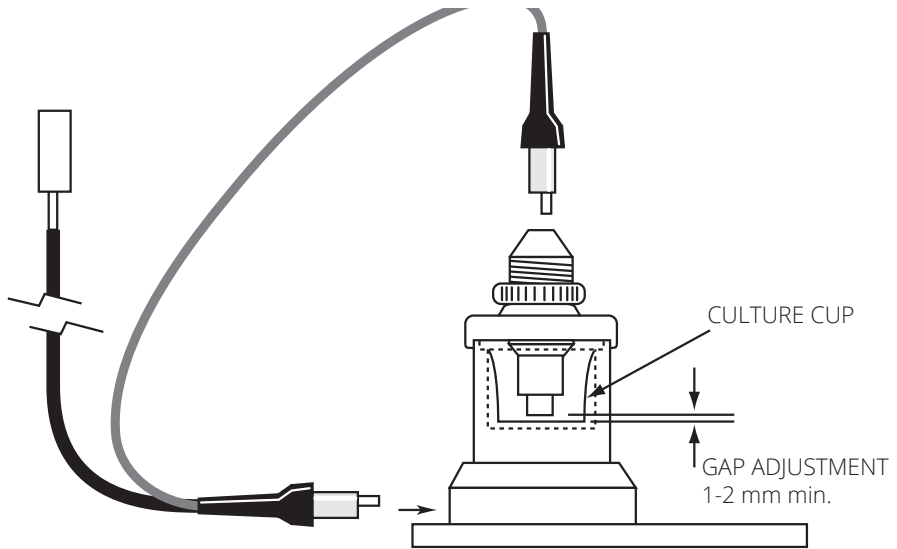

Fig. 3—Assembled EndOhm showing the appropriate gap between the membrane and the electrode

Electrode Preparation

For resistance measurement, the **EndOhm** can be used directly without conditioning the electrode.

For voltage measurements, silver/silver chloride voltage electrodes may exhibit a small voltage drift when stored dry and are then newly immersed in electrolyte solution. This drift may affect potential measurement accuracy, but not resistance measurements.

In order to stabilize the electrodes:

1. Fill the chamber with saline solution (for example, 0.1-0.15M KCl).
2. Place the upper cap electrodes onto the lower chamber.
3. Connect the upper cap and the lower chamber to the **99916** Endohm cable as shown in Fig. 3.

-
4. Connect other end of the cable to the **EVOM™ Manual** with the power off. The voltage electrodes are shorted together internally when they are connected to the instrument and the power is off. With the voltage electrode connector pins short-circuited for several hours, the asymmetrical potential difference across the low voltage electrodes is reduced. The inter-electrode DC potential may be a few millivolts or less, but it should be quite stable. Equilibration time will vary from approximately 2-12 hours. If the offset is greater than 10mV, leave the saline solution in the chamber overnight with the cable connected to the **EVOM™ Manual** and the power off.

TIP: To check the calibration of the **EVOM™ Manual**, plug a **91750** 1000 Ω test resistor into the port on the front of the **EVOM™ Manual**. The **EVOM™ Manual** should display 1000 $\Omega \pm 1\Omega$. If necessary, use a small screw driver to adjust R Adj potentiometer on the front of the **EVOM™ Manual**. Set the resistance to 1000 Ω .

OPERATING INSTRUCTIONS

1. Measurement using the **EndOhm** requires the cell culture cup to be transferred into the chamber. Place a blank culture cup in the **EndOhm** chamber.
2. Add an appropriate electrolyte to the culture cup and the chamber. Make sure that the height of the fluid inside the chamber is no more than 3–4mm so that when the cap assembly is inserted, fluid will not overflow the top of the culture cup. With the cap in place, the height of the fluid in the chamber should be at the same level as inside the cup in order to avoid hydrostatic pressure on the membrane.
3. Position the cap on the chamber. To obtain reproducible and accurate readings, it is important that the cap is well-seated on the chamber, so that the top electrode is centered.
4. Through the transparent side wall of the chamber, look for air bubbles trapped between the top electrode and the surface of the electrolyte. Air bubbles will cause the resistance and voltage readings to be very unstable. Gently shake the **EndOhm** or reinsert the electrode to remove any air bubbles.

For complete instructions on using your **EVOM™ Manual**, refer to the **EVOM™ Manual** Instruction Manual. Quick start instructions are below.

Voltage Measurements

1. Power on the **EVOM™ Manual** using the power switch on the rear panel and connect the **EndOhm** chamber to the meter.
2. Add media to the lower chamber. The media volume should be enough to cover the basal membrane, but not enough to overflow into the apical side when the well cup is inserted into the chamber.
3. Add media to a blank cup, a cell culture insert without cells.

4. Insert the electrode into the blank cup. Measure the resistance of a blank culture cup (no cells). A steady ohms reading of the solution resistance should result. The value of the blank always adds to the total resistance measured across a tissue culture membrane. See “APPENDIX A: RESISTANCE CALCULATIONS” on page 14 for a more detailed discussion of the source of the blank resistance and information on calculating true tissue resistance and unit areas resistance (the value that is normally reported).

NOTE: The blank resistance must be measured and then subtracted from the resistance reading across tissue in order to obtain the true tissue resistance.

NOTE: The resistance of the blank for the **EndOhm-6G** is slightly higher than that of the **ENDOHM-12G** and the **ENDOHM-24G-SNAP** because of its construction.

5. On the **EVOM™ Manual**, press **Setup** to access the **Setup** menu.
 - **Select Plate**–Choose the plate size.
 - **Select Mode Units** – Choose volts or millivolts (the normal mode is millivolts).
 - **Electrode Equilibration** – Zero the electrodes’ galvanic charge in saline.
 - Press the **Probe Null** button. Push the **NULL** button. Wait for the second message stating “Solution value 0.0” before returning. This action removes any voltage offsets on the electrodes. Then activate the **Enable/Disable** radio button to offset the electrode potential.
 - Press **Return** to navigate back to the main menu.
6. Insert a USB drive into the USB port on the side of the **EVOM™ Manual** and begin measuring by pressing the foot switch or touching the **Store** button on the screen. When the file storing selection notification appears, press **Store**.
7. Remove the USB thumb drive to transfer the data file to your computer as a CSV file (Excel).

NOTE: The bottom electrode is connected to instrument ground. The top electrode will produce positive DC voltage readings for positive voltage and negative for negative voltages, relative to the bottom electrode. This is opposite in sign from the **STX4** electrode. For example, a culture cup which produces a reading of 2mV while the **STX4** will produce a -2mV reading with the **EndOhm**.

Resistance Measurements

1. Power on the **EVOM™ Manual** using the power switch on the rear panel and connect the **EndOhm** chamber to the meter.
2. Add media to the lower chamber. The media volume should be enough to cover the basal membrane, but not enough to overflow into the apical side when the well cup is inserted into the chamber.
3. Add media to a blank cup, a cell culture insert without cells.
4. Insert the electrode into the blank cup. Measure the resistance of a blank culture cup (no cells). A steady ohms reading of the solution resistance should result. The value of the blank always adds to the total resistance measured across a tissue culture membrane. See “APPENDIX A: RESISTANCE CALCULATIONS” on page

14 for a more detailed discussion of the source of the blank resistance and information on calculating true tissue resistance and unit areas resistance (the value that is normally reported).

NOTE: The blank resistance must be measured and then subtracted from the resistance reading across tissue in order to obtain the true tissue resistance.

NOTE: The resistance of the blank for the **EndOhm-6G** is slightly higher than that of the **ENDOHM-12G** and the **ENDOHM-24G-SNAP** because of its construction.

5. On the **EVOM™ Manual**, press **Setup** to access the **Setup** menu.
 - **Select Plate**—Choose the plate size.
 - **Select Mode Units** – Choose OHMS or KOHMS for making resistance measurements. Select the resistance range (auto or 10,000 ohms).
 - **Calibrate**—Press Calibrate to calibrate the electrode. (This uses a 10 K Ω 0.1% resistor).
 - **Blank Handling** – To subtract a blank well (including the fluid and electrode resistances), place the electrode in a blank well and press **Reading**. Press the **Blank Enable** radio button to subtract the blank value..
 - Press **Return** to navigate back to the main menu.
6. Insert a USB drive into the USB port on the side of the **EVOM™ Manual** and begin measuring by pressing the foot switch or touching the **Store** button on the screen. When the file storing selection notification appears, press **Store**.
7. Remove the USB thumb drive to transfer the data file to your computer as a CSV file (Excel).

MAINTENANCE

Cleaning

After each use of your **EndOhm**, flush the chamber thoroughly with distilled water, and allow the lower and upper electrodes to soak in the distilled water for a minimum of one minute. Discard the water and dry both the upper and lower electrodes with a Kimwipe (lint-free, absorbent wipe). Do not use anything more abrasive than a cotton swab for cleaning the **EndOhm**.

Between experiments, rinse old growth buffer from the chamber with distilled water. Rinse with distilled water before filling the chamber with new growth buffer.



CAUTION: The silver pellets are porous, and alcohol will soak into them. The final water rinse may pull alcohol from the pellets. Alcohol that has soaked into the pellet could kill the cell layer and show up as drift.

With use, the electrode surface can become coated with protein or other foreign materials. This build-up, or contamination, can degrade the performance of the system. Periodically clean your **EndOhm** electrodes with Tergazyme, a proteolytic detergent manufactured by Alconox.

1. Rinse with the electrodes with distilled water and dry them.
2. Make a 1% solution of Tergazyme according to the manufacturer's instructions.
3. Allow the upper and lower electrodes of the **EndOhm** to soak in the Tergazyme solution, with the exposed electrode surfaces fully immersed. During soaking, the surfaces of the electrodes may be brushed with a soft brush (like a tooth brush), if desired. The soaking time varies according to your maintenance schedule and the frequency of your cleaning.
 - Soak overnight when electrodes have not been on a routine maintenance cleaning schedule.
 - Soak 30–60 minutes if you are on a weekly cleaning schedule.
 - Soak 5 minutes if you clean your electrodes daily.
4. Rinse well with distilled or de-ionized water. Allow them to air dry and store the electrodes dry away from exposure to sunlight.

Storage

For long term storage (more than 5 days), store the **EndOhm** dry.



CAUTION: Long-term storage in a UV hood could cause cracking in the clear plastic chamber.

Sterilization

The **EndOhm** may be sterilized with a ethylene oxide (EtO) or a 70/30 mix of alcohol to water. A bactericide like **Cidex** (WPI #7364) can be used, as needed. No other solvents should be used. After sterilization, the electrodes should be thoroughly rinsed with a sterile perfusing solution (growth buffer) before making membrane measurements.

! **CAUTION: DO NOT AUTOCLAVE THE ENDOHM.** Autoclaving can cause the transparent section of the chamber to become crazed. Repeated autoclaving might also damage the seal of the electrode.

Re-Chloriding the Electrode

The current electrodes consist of solid silver. The surface is chlorided with gray colored silver chloride to enhance stability and provide a faster response time. Over time, this silver chloride surface may wear off and leave the silver exposed. This should not change the performance of the **EndOhm** significantly.

Once a week, or as needed, the electrode can be re-chlorided. Immerse the tips of the electrode in common a 5% solution of sodium hypochlorite (bleach) for 10 minutes or until a black-purple layer is formed. Do not use a solution stronger than 3–6% sodium hypochlorite. Rinse well in distilled water and flush with the growth buffer prior to use. Test the electrode with a **CaliCell-12** (WPI #CALICELL-12).

Fig. 4 and Fig. 5 show an **EndOhm** that has been re-chlorided.



Fig. 4—(Left) ENDOHM-12G shown that has not been chlorided enough

Fig. 5—(Right) Properly chlorided EndOhm (note the darker color)

! **CAUTION:** Ensure that only the electrode tip is exposed to the sodium hypochlorite. The threaded section of the top electrode and the cap are made of steel or black anodized aluminum. Sodium hypochlorite will attack these surfaces. The solution must not contact these surfaces while chloriding the electrodes

Once every month or two, as needed, you may remove the biological remnants from

the electrode. Use an enzymatic cleaner like **Enzol** (WPI #7363-4), and follow the manufacturer's instructions to clean the tips of the electrodes. Rinse well in distilled water. See Fig. 6 and Fig. 7.



Fig. 6—(Left) A clean EndOhm surface with no spots or irregularities

Fig. 7—(Right) Notice the center tip and the small ring on the top section. These may require the use of a cotton swab to clean.

Rarely you may need to resurface the electrode. Dry the electrodes and lightly “sand” or buff just the tip of the electrode with a very fine grain Emory paper (600 grit or more) or used an “ink” eraser to lightly buff the electrode ends. Remove only a very thin surface layer of the pellet. After sanding the pellet, re-chloride the tips using the instructions above.



CAUTION: Repeated sanding will eventually remove the Ag/AgCl pellet. When sanding no longer improves the voltage readings, the electrode needs to be replaced.

ACCESSORIES

Table 1: Accessories

Part Number	Description
7364-4	Cidex OPA
99916	Replacement Endohm cable
610053	4mm Spacer disk
610057	6mm Spacer disk
EVOM™ Manual	Epithelial Tissue Voltohmmeter

TROUBLESHOOTING

Issue	Possible Cause	Solution
Resistance reading drifts or is unstable	Charger is connected to the meter	The meter reading can become unstable due to the loss of electrical isolation when the charger is connected to the AC power. To ensure stability of readings, always disconnect the charger from the meter when making measurements.
	Meter needs set	Use the R ADJ calibration screw on the front panel to adjust the resistance value to 1000Ω, using the test resistor.
	Old electrode probe	Use the test resistor to verify the meter is functioning correctly. The meter display should read 1000Ω.
Unusually low or high reading	Culture cup is incorrectly positioned	Move electrode to a different height position.
		If you have upper mount cups (usually with a plastic support cone), verify that there is about 2mm of clearance over the bottom electrode set.
	Conductive contamination between electrodes	Inspect the electrode surfaces for material which could form a conductive bridge between the upper and lower electrodes causing the upper and lower electrodes to be in the same contiguous solution without an electrical separation. If the material cannot be removed, the electrode should be replaced.
	Molarity of buffer solution changed	A 1% change in 100mM molarity can cause large reading errors.
	A bad cable	Continuous low resistance readings, even when dry could be caused by a bad cable. Try a replacement cable (WPI #99916).
	Dirty electrodes	Clean the electrodes. (See “Cleaning” on page 9.)
Cell culture or media problem	If the cell culture has been given sufficient time to achieve confluence, and the reading is stable but significantly lower than expected, then the problem is probably related to the cell culture. Electrode failure will not generally cause a lower than expected yet stable reading. Use the test resistor to verify the meter is functioning correctly. The meter display should read 1000Ω.	

Issue	Possible Cause	Solution
Voltage reading is unstable	Low battery in the EVOM™ Manual	Ensure that the charger is connected and plugged into a live wall outlet. Wait one minute and test again. If the voltage output is not zero (in plain culture media) and the battery pack is fully charged, the instrument is malfunctioning. Before contacting WPI Technical Support for assistance, recharge the instrument for 24 hours and repeat the procedure.
	Electrode too close to strong electromagnetic radiation device	Move the system to a different area away from sources of electromagnetic fields. Electromagnetic field sources could include computers, MRI equipment, magnetic stirrers, etc.
	Power line or output jack connected to a recording device causing noise	Remove the connection to the recording device to eliminate that problem.

NOTE: If you have a problem/issue with that falls outside the definitions of this troubleshooting section, contact the WPI Technical Support team at (941) 371-1003 or technicalsupport@wpiinc.com.

APPENDIX A: RESISTANCE CALCULATIONS

Resistance

The value of the blank always adds to the total resistance measured across a tissue culture membrane. (See below.) *The blank resistance must be measured and then subtracted from the resistance* reading across the tissue in order to obtain the true tissue resistance.

For example, suppose the resistance through a 0.15M KCl solution and across the membrane support (with no tissue present) of a 12-well cell culture insert measures 130Ω. This is the blank reading for that cell culture insert. (Resistance may vary for culture cups made by other manufacturers.) In this example, using 800 Ω as the sample measurement, the calculated resistance for the tissue itself (R_{tissue}) is:

$$\begin{aligned} R_{\text{Total}} &= 800 \\ R_{\text{blank}} &= 130 \Omega \\ R_{\text{blank}} + R_{\text{true tissue}} &= R_{\text{Total}} \\ R_{\text{true tissue}} &= R_{\text{Total}} - R_{\text{blank}} \\ R_{\text{true tissue}} &= 800\Omega - 130\Omega = 670\Omega \end{aligned}$$

Resistance value of the “blank” insert

The resistance measurement of a blank insert is not background resistance due to the resistance of the blank filter. Rather, if the filter membrane is removed from the insert, the resistance reading of the insert will remain the same, because the background resistance reading is due mainly to the small gap between the bottom of the cell culture insert and the bottom of the cell culture plate.

This gap is about 1mm, with some insert brands having a slightly larger gap than others. The variation in this gap is the cause of the difference between blank readings of different brands. The smaller the gap, the higher the electric resistance. *The resistance of the filter membrane itself is actually negligible.*

If an **ENDOHM-24G-SNAP** or **ENDOHM-12G** chamber is used, the blank resistance becomes near zero, because the external electrode is directly underneath the filter and the gap does not exist.

Unit Area Resistance

As the resistance is inversely proportional to the area of the tissue, instead of reporting resistance, typically the product of the resistance and the area is calculated and reported. The unit area resistance is independent of the area of the membrane used and may be used to compare data obtained from inserts of different sizes.

The **unit area resistance** is obtained by **multiplying** the meter readings by the effective surface area of the filter membrane. The dimension is Ωcm². The resistance is **inversely** proportional to the surface area. Thus, the larger the membrane, the lower the resistance.

Resistance of a unit area = Resistance (Ω) x Effective Membrane Area* (cm²)

* See manufacturing specifications for the particular insert

Unit Area = 1cm²

The unit area resistance is independent of the area of the membrane used and may be used to compare data obtained from inserts of different sizes.

Continuing with the previous example, in which the $R_{\text{true tissue}} = 670\Omega$, if an effective membrane diameter (d) were 1.05cm, the unit area resistance would be:

$$\begin{aligned}\text{Resistance x Effective Membrane Area} &= 670\Omega \times \pi d^2/4 \\ &= 670\Omega \times (3.14) \times (1.05\text{cm})^2/4 \\ &= 580\Omega\text{cm}^2\end{aligned}$$

580 Ω is the resistance of a unit area of 1cm².

The larger the membrane, the lower the resistance. The dimension is Ωcm^2 , not Ω/cm^2 . This may be confusing to a new user who might expect to divide to find the resistance of a unit area.

A further illustration may help to reinforce this concept:

Assuming a 1cm² membrane has a resistance of 500 Ω , then a 5cm² membrane will have a resistance of 100 Ω , not 2,500 Ω , because the resistance is *inversely* proportional to the area. Accordingly, if a 5cm² membrane has a resistance of 100 Ω , then the resistance of a 1cm² membrane will be 100 Ω x 5cm² = 500 Ωcm^2 because the smaller membrane is 1/5 the size and the resistance will therefore be five times greater.

APPENDIX B: TESTING THE ENDOHM

You can use this procedure to verify that your **EndOhm** is working properly. To perform this test, you will need:

- EVOM™ Manual
- 20mM KCl stock solution
- 80mM KCl stock solution
- Spacer disk included with your **EndOhm** (4mm gauge for **ENDOHM-6G** or a 6mm gauge for the **ENDOHM-12G** or **ENDOHM-24G-SNAP**)

1. Check the resistance calibration of the **EVOM™ Manual** by plugging in a 1000Ω test resistor (WPI #91750). The **EVOM™ Manual** should display 1000Ω ± 1Ω. If necessary, adjust the resistance to 1000Ω. To adjust the resistance, insert a small screwdriver through the R ADJ hole on the front panel of the **EVOM™ Manual** and rotate the screw to adjust the resistance up or down.
2. Adjust the position of the upper electrode on your **EndOhm** to the correct distance from the bottom of the chamber. A plastic spacer disk is provided with your **EndOhm** for this purpose. A 4mm gauge disk is provided for an **ENDOHM-6G**, and a 6mm gauge disk is provided for the **ENDOHM-12G** or **ENDOHM-24G-SNAP**.
 - a. Place the disk flat side down into the center of the **EndOhm** lower chamber.
 - b. Loosen the upper electrode locking nut, and place the upper electrode cap assembly onto the lower chamber.
 - c. To set the correct test distance, adjust the position of the upper electrode until its face comes into contact with the upper surface of the spacer disk. The underside of the cap should be resting level and in full contact with the rim of the lower chamber. The cap should not be elevated away from the lower chamber, tilted or mechanically unstable. This is an indication that the upper electrode is projecting too deeply into the chamber.
 - d. When the upper electrode is properly adjusted, secure it by re-tightening the locking thumb nut.
 - e. When your height adjustment is complete, remove the spacer disk.
3. Each model of **EndOhm** requires a different volume of test solution. Use a pipette or syringe to measure the correct volume of the 80mM KCl stock solution into the lower chamber of the **EndOhm**.
 - **ENDOHM-6G:** Use 2mL
 - **ENDOHM-12G:** Use 5mL
 - **ENDOHM-24G-SNAP:** Use 11mL
4. Place the upper cap electrode onto the lower chamber.
5. Connect the **EndOhm** to the **EVOM™ Manual** using an **EndOhm** cable (WPI #99916) with the **EVOM™ Manual** powered off.

NOTE: The electrodes must be fully wetted to ensure a stable and repeatable reading.

Let the **EndOhm** soak in the test solution for a minimum of 15 minutes before taking measurements.

6. Power up the **EVOM™ Manual** and set it to resistance mode.
7. If the reading is stable, record the resistance measurement. In order to pass the performance test, the resistance should fall within or very close to the limits for each test solution as shown below.

Expected Resistance Readings

Test Solution	ENDOHM-6G	ENDOHM-12G	ENDOHM-24G-SNAP
20 mM KCl	111 Ω ± 45 Ω	67 Ω ± 26 Ω	39 Ω ± 16 Ω
80mM KCl	29 Ω ± 17 Ω	17 Ω ± 13 Ω	11 Ω ± 10 Ω

NOTE: As a general guideline, the resistance at 20mM should be roughly 4 times greater than the resistance measured at 80mM.

NOTE: The standard readings in the table above have been generated from statistical data. If test readings do not meet these criteria, it does not mean that the **EndOhm** is defective. If resistances are slightly higher or lower than expected, temperature may be affecting the measurement.

8. Switch the **EVOM™ Manual** to millivolt mode. Observe the voltage offset. If the offset is less than 5mV, proceed to the next step.

If the offset exceed 5mV, then the electrodes may be galvanically equilibrated by allowing them to soak in 80mM KCl while connected to the **EVOM™ Manual** with the **EVOM™ Manual** switched off for several hours or overnight. Check the voltage offset again.
9. Discard the 80mM KCl solution from the lower chambers, and fill them with distilled water. Allow the upper and lower electrodes to soak in the distilled water for a minimum of one minute. Discard the solution.
10. Dry both the upper and lower electrodes with a Kimwipe or similar lint-free absorbent wipe.
11. Using a pipette or syringe, measure the correct test volume from step 3 of 20mM KCl stock solution. Fill the lower chamber.
12. Repeat steps 4–7. Check your resistance readings against the table shown in step 7. If your resistance readings fall within the specifications, then your **EndOhm** is functioning properly.

INDEX

Symbols

7364 11
99916 11, 12
610053 11
610057 11

A

accessories 11
Ag/AgCl 4
AUTOCLAVE 10

B

battery 13
blank culture cup 7
blank cup 4
blank resistance 14

C

cap 6
cell culture 12
chloridized 10
Cidex 10
cleaning 9
contamination 9

E

electrical isolation 12
electromagnetic radiation device 13
Enzol 11
ethylene oxide 10

H

height of the top electrode 4

L

long term storage 9

P

parts list 2

R

R ADJ 12
re-chloridize 10
resistance calculations 14
resistance measurement 5, 7
resurface the electrode 11
returns 3

S

sanding 11
sodium hypochlorite 10
sterilization 10
STX2 7

T

test resistor 12
troubleshooting 12

U

unit area resistance 14
unpacking 3
UV hood 9

V

voltage measurements 5, 6

WARRANTY

WPI (World Precision Instruments, Inc.) warrants to the original purchaser that this equipment, including its components and parts, shall be free from defects in material and workmanship for a period of 90 days* from the date of receipt. WPI's obligation under this warranty shall be limited to repair or replacement, at WPI's option, of the equipment or defective components or parts upon receipt thereof f.o.b. WPI, Sarasota, Florida U.S.A. Return of a repaired instrument shall be f.o.b. Sarasota.

The above warranty is contingent upon normal usage and does not cover products which have been modified without WPI's approval or which have been subjected to unusual physical or electrical stress or on which the original identification marks have been removed or altered. The above warranty will not apply if adjustment, repair or parts replacement is required because of accident, neglect, misuse, failure of electric power, air conditioning, humidity control, or causes other than normal and ordinary usage.

To the extent that any of its equipment is furnished by a manufacturer other than WPI, the foregoing warranty shall be applicable only to the extent of the warranty furnished by such other manufacturer. This warranty will not apply to appearance terms, such as knobs, handles, dials or the like.

WPI makes no warranty of any kind, express or implied or statutory, including without limitation any warranties of merchantability and/or fitness for a particular purpose. WPI shall not be liable for any damages, whether direct, indirect, special or consequential arising from a failure of this product to operate in the manner desired by the user. WPI shall not be liable for any damage to data or property that may be caused directly or indirectly by use of this product.

Claims and Returns

Inspect all shipments upon receipt. Missing cartons or obvious damage to cartons should be noted on the delivery receipt before signing. Concealed loss or damage should be reported at once to the carrier and an inspection requested. All claims for shortage or damage must be made within ten (10) days after receipt of shipment. Claims for lost shipments must be made within thirty (30) days of receipt of invoice or other notification of shipment. Please save damaged or pilfered cartons until claim is settled. In some instances, photographic documentation may be required. Some items are time-sensitive; WPI assumes no extended warranty or any liability for use beyond the date specified on the container.

Do not return any goods to us without obtaining prior approval and instructions from our Returns Department. Goods returned (unauthorized) by collect freight may be refused. Goods accepted for restocking will be exchanged or credited to your WPI account. Goods returned which were ordered by customers in error are subject to a 25% restocking charge. Equipment which was built as a special order cannot be returned.

Repairs

Contact our Customer Service Department for assistance in the repair of apparatus. Do not return goods until instructions have been received. Returned items must be securely packed to prevent further damage in transit. The Customer is responsible for paying shipping expenses, including adequate insurance on all items returned for repairs. Identification of the item(s) by model number, name, as well as complete description of the difficulties experienced should be written on the repair purchase order and on a tag attached to the item.

* *Electrodes, batteries and other consumable parts are typically warranted for 30 days only from the date on which the customer receives these items. EVOM™ electrodes are warranted for 90 days.*



WORLD
PRECISION
INSTRUMENTS